



Product Data Sheet

Product : Tank Cleaning Machine
 Model : LT & LT-FT

The Butterworth LT automated tank cleaning machine provides 360° impact indexed coverage for the cleaning of the inside of tanks and process vessels.

Industries

The Butterworth LT is a highly versatile machine and is applicable in most all types of tanks for process, storage, and transportation. Tank capacities range from 500-150,000 gallons (2-570 M³) for one machine per tank and larger tanks where multiple machines are installed.

Operational

The Butterworth LT machine creates a pattern matrix similar to a ball of twine (see cleaning pattern simulation in the lower right hand corner of this page). A complete pattern is established when 65 axial revolutions of the body have been completed. During the process of this pattern build out, 4 cycles are established with each cycle increasing the density of the pattern matrix.

User Benefits

- Elimination Of Confined Space Entry
- High Jet-Stream Impact
- Reduced Cleaning Times
- Reduced Effluent Generation
- Reduced Energy Costs
- Improved Capital Equipment Utilization

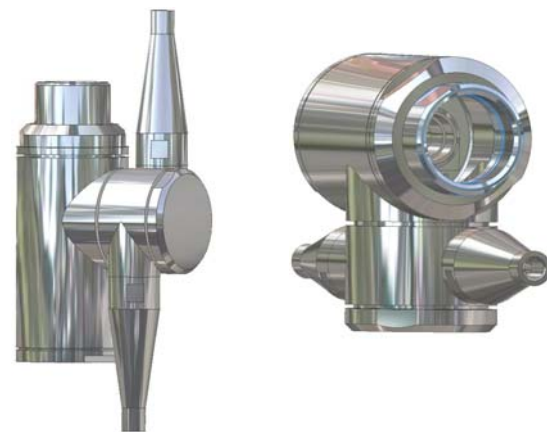

Specifications - Summary

Materials Of Construction (As Standard):

- 316 Stainless Steel/CD4-MCU Duplex S/S
- See manual for parts detail

Weight:

- 15 lbs. (6.8 kg)

Lubrication:

- Flow-Through (Media Lubricated)
- Sealed Gearbox

Pressure Range:

- 0-300 PSI (21 Bar)

Jet-Length Radius:

- 0-58' (17.68 M)

Temperature Range:

- Static : 300°F (149°C)
- Operational : 300°F (149°C)

Inlet Connection Type:

- 1 ½" NPT (F)
- 1 ½" BSP (F)
- Weld
- Others on request

Minimum Tank Opening Requirement:

- 5.613" (142.56 mm)

Surface Finish:

- ≤ 25 Ra μ (Micro Inch) - External
- Others on request

Packaged Dimensions & Weight / Per Machine

- DIM: 14"L x 6"W x 10"H
- Weight: Gross = 15.2 lbs Net = 15.0 lbs

Dimensional Drawing Number:

- DWG1637

General Dimensions

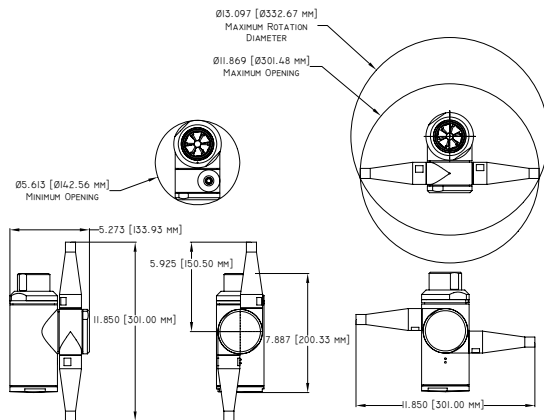

Type LT - Model Reference Table

Model #	Nozzles	Conn.	Lubrication	
LT6ZM3NOFT	2 x 6mm	1.50" NPT(F)	Media	
LT8Z31NO	2 x 8mm		Oil/Grease	
LT8Z31NOFT	2 x 8mm		Media	
LT10Z21NO	2 x 10mm		Oil/Grease	
LT10Z21NOFT	2 x 10mm		Media	
LT12Z21NO	2 x 12mm		Oil/Grease	
LT12Z21NOFT	2 x 12mm		Media	
LT6ZM3BOFT	2 x 6mm		1.50" BSP(F)	Media
LT8Z31BO	2 x 8mm			Oil/Grease
LT8Z31BOFT	2 x 8mm			Media
LT10Z21BO	2 x 10mm	Oil/Grease		
LT10Z21BOFT	2 x 10mm	Media		
LT12Z21BO	2 x 12mm	Oil/Grease		
LT12Z21BOFT	2 x 12mm	Media		

Custom configurations on request.

Cleaning Pattern Simulation

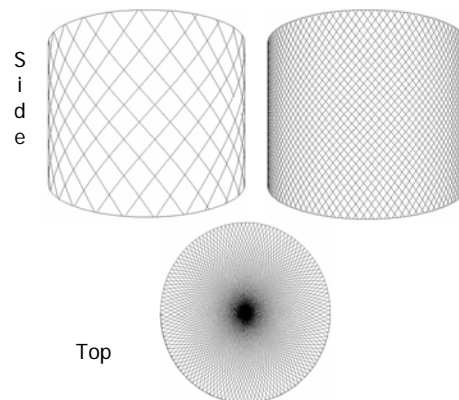

Product Data Sheet

Product : Tank Cleaning Machine
 Model : LT & LT-FT



Flow/Pressure

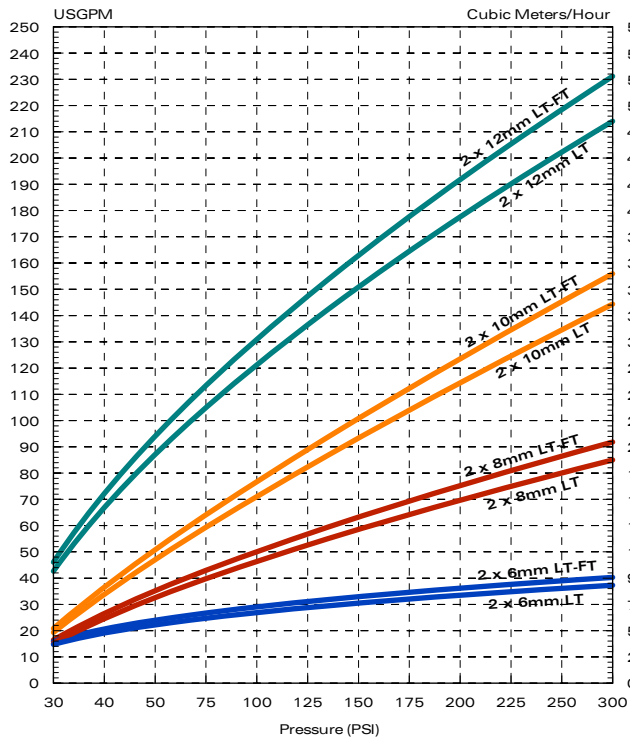

Pattern Time

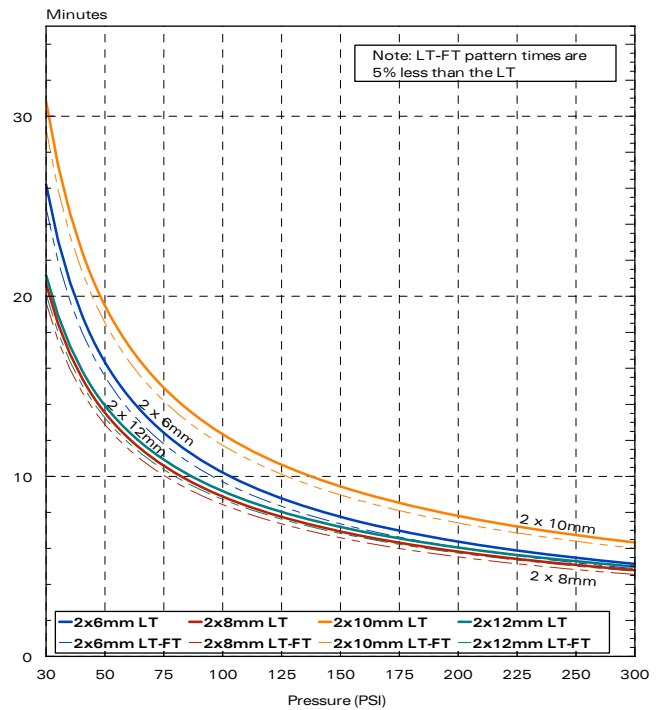

Jet-Length (Radius)

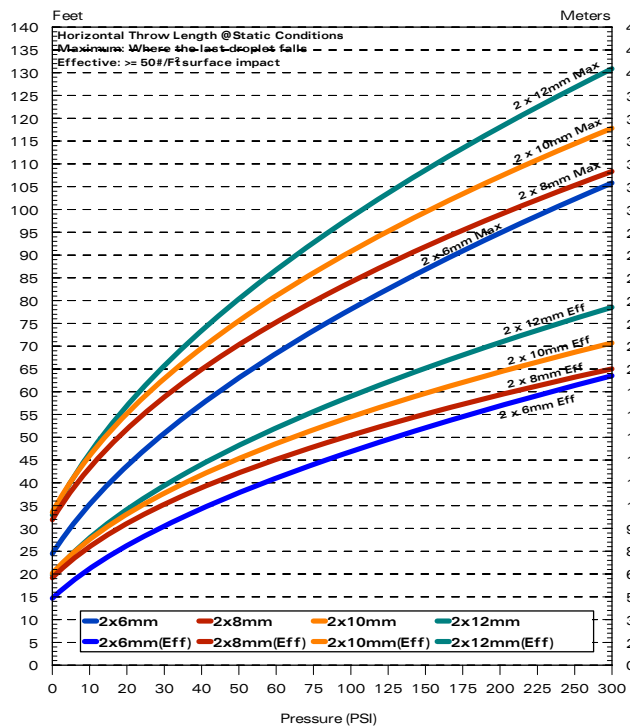

Impact Pressure @ 100 PSIG

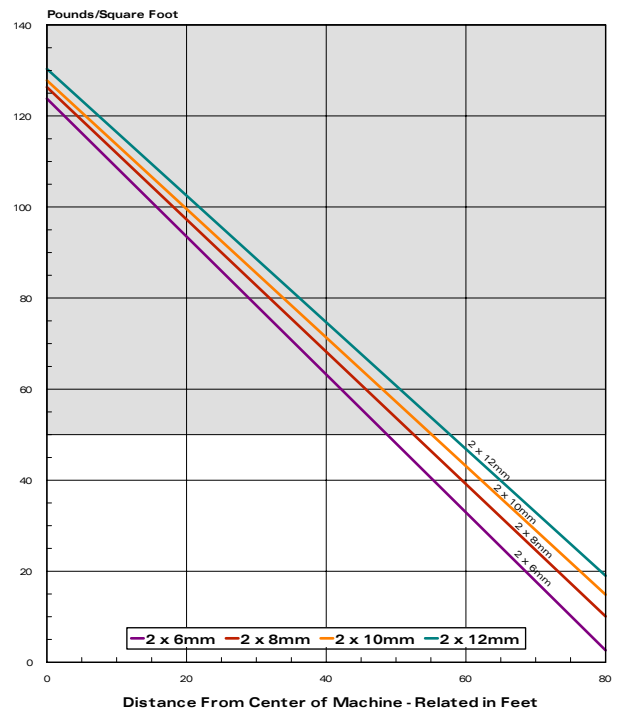

Important Notice:

The curves presented here are summary in nature. For a complete set of curves, contact Butterworth

Contact Butterworth for installation and engineering assistance.